

TMR6218LA

18 Channels TMR Magnetic Pattern Recognition Sensor

General Description

The TMR6218LA is a type of 18 channels magnetic pattern recognition sensor with high consistency, high sensitivity and high signal-to-noise ratio performance, it is used for detecting full size of the paper bills, bank notes and security documents with magnetic anti-counterfeiting consists. The TMR6218LA consist of TMR magneto-resistance sensor, high-quality magnet, high-strength plastic base and durable non-magnetic stainless steel cover; and the TMR6218LA is 21mm.

Features and Benefits

- High sensitivity and excellent gap performances
- Sensitivity matching of each channel
- Output voltage is independent of scanning speed
- Differential output, high CMRR performance
- Durable metal case, suitable for long time and heavy load situations
- 180mm detection width, no non-detection area
- 18 channels, 10mm detection width per channel

Applications

- ATM
- Bill counter and validator
- Bill sorter
- Magnetic detection of the paper bills

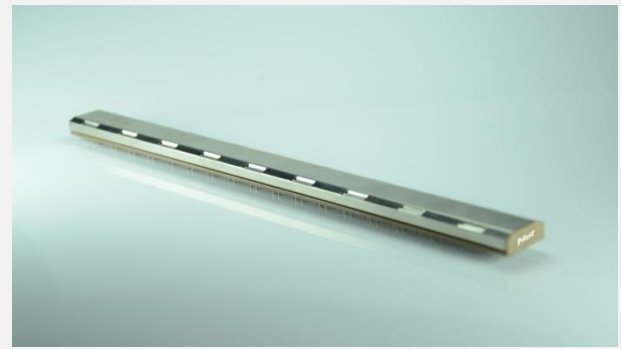

TMR6218LA

Pin Configuration

Block Diagram (Top View)

Pin No.	Symbol	Description
1	$V_{O+} (n)$	Differential positive output of channel n
2	$V_{CC} (n)$	Power supply of channel n
3	$V_{O-} (n)$	Differential negative output of channel n
4	GND (n)	Ground of channel n
5	Shell GND	Shell GND, connected to shielding ground

Absolute Maximum Ratings

Parameter	Symbol	Limit	Unit
Maximum Supply Voltage	V_{CC}	5.5	V
Operating Temperature	T_A	-20 ~ 65	°C
Storage Temperature	T_{stg}	-30 ~ 85	°C
Operating Humidity	HMD	10 ~ 90 (no dew)	%RH
ESD (HBM)	V_{HBM}	2000	V

Electrical Property ($V_{CC}=5V$, $T_A=25^\circ C$)

Parameter	Symbol	Conditions	Min	Typ	Max	Unit
Sensitivity	$S^{(1)}$	$V_{CC}=5V$		TBD		V_{PP}
Resistance	R	No external magnetic field	0.5		3	kOhm
Output Offset Voltage	V_{OS}	$V_{CC}=5V$	-75		75	mV/V
Noise	$V_N^{(2)}$	$V_{CC}=5V$		50		μV_{PP}
Surface Magnetic Field	B	On sensing surface(S pole)		800		G
Sensitivity Deviation	ΔS	$(S_{MAX} - S_{MIN}) / S_{MEAN}$	0		0.67	V/V
Number of Channels	C			18		
Detection Width per Channel	W			10		mm
Resolution	T			0.475		mm

Notes:

- (1) According to the MultiDimension sensitivity measurement.
- (2) The amplifier's gain is 10000V/V@1kHz, no external magnetic field applied, measure the peak-to-peak voltage V_{PP} , then noise $V_N = V_{PP}/10000$.

Caution for Use

- The sensor contains a permanent magnet, it will cause the recordable magnetic media damaged, such as cassette tapes, floppy disks, credit cards, hard drives, keep it away from such types of magnetic media.
- To avoid the ferromagnetic particles being collected from a dirty environment.
- Magnets tend to snap to each other or the magnetic metals, be careful when handling the sensor not to apply mechanical shock, otherwise the sensors might be abnormal or break.
- Do not place the sensor near the person who has an electronic medical device. It is very dangerous and may cause malfunction of an electronic medical device.
- Magnetic devices may be subject to special transport regulations.
- To avoid the abrasion of the sensor's metal case or stuck the banknote, about 0.1mm gap between the sensor and the opposite side such as rollers is recommended to reduce the pressure of the sensor's metal case.
- To avoid excessive force on terminals, please mount the sensor's base firmly on the PCB and solder all the terminals.
- Hand soldering should be applied, the soldering temperature should be $350 \pm 10^\circ C$ less than 3 seconds or $260 \pm 5^\circ C$ less than 10 seconds

Outline Drawing and Dimensions

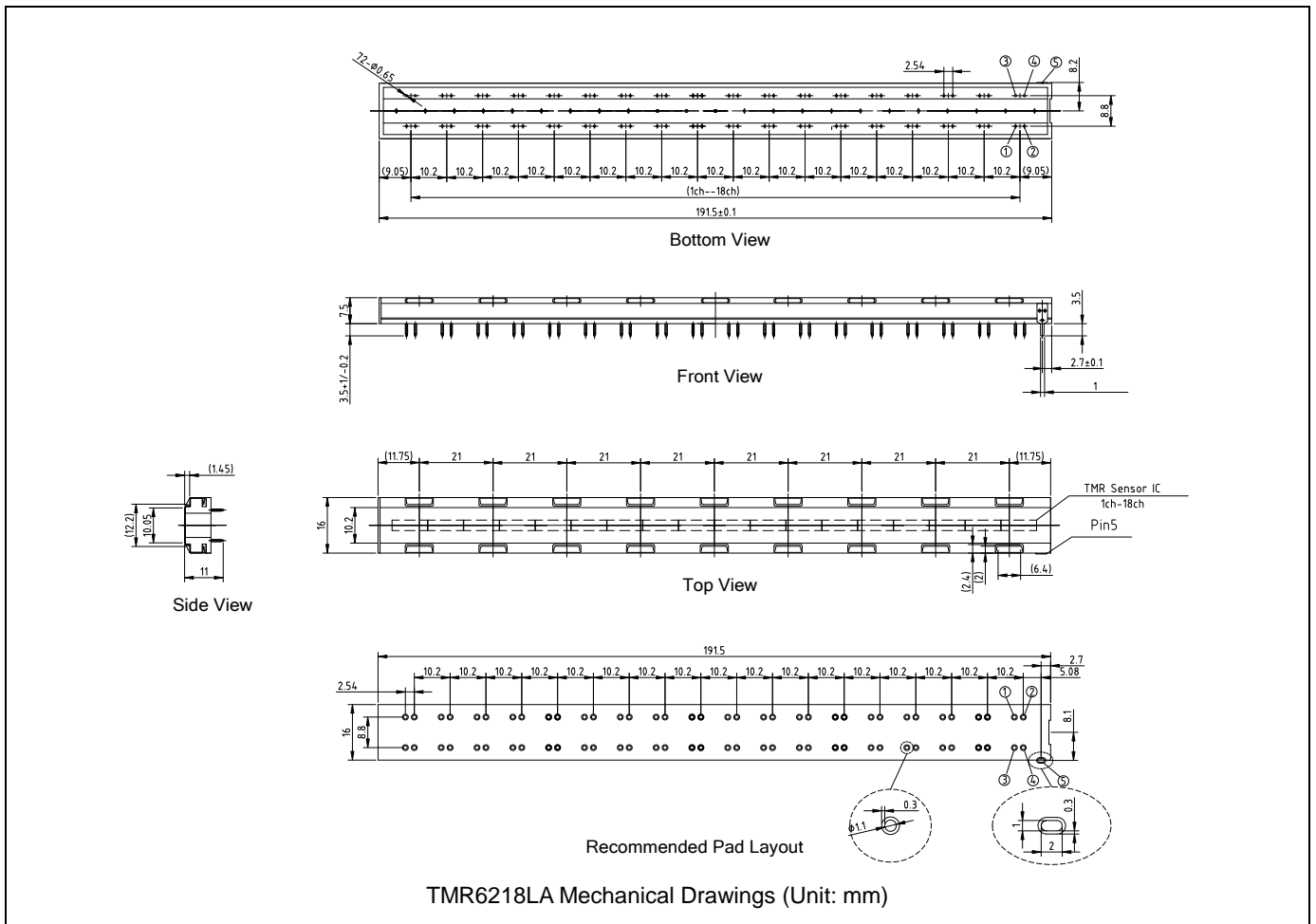

Notes:

The notch pitch on metal cover of the TMR6218LA is 21mm.

Recommended Application Circuit

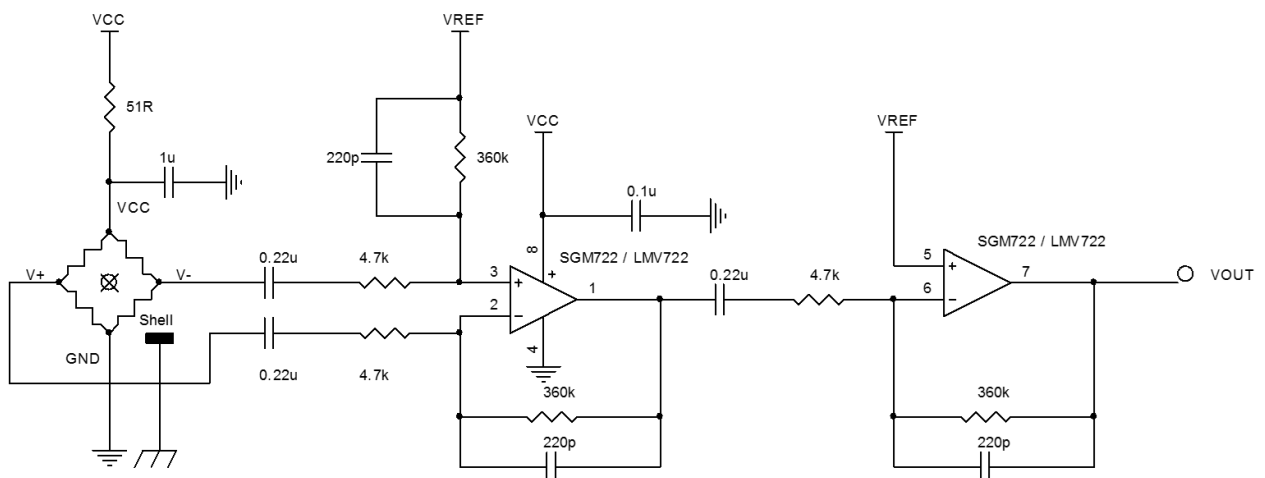

Notes:

Shell GND pin should be connected to the shielding ground.



American Electronic Components Inc.

1101 Lafayette Street, Elkhart, Indiana 46516, United States of America.

Web: www.aecensors.com Email: sales@aecensors.com

Toll: 888 847 6552, Tel: +1 574 293 8013

The information provided herein by MultiDimension Technology Co., Ltd. (hereinafter MultiDimension) is believed to be accurate and reliable. Publication neither conveys nor implies any license under patent or other industrial or intellectual property rights. MultiDimension reserves the right to make changes to product specifications for the purpose of improving product quality, reliability, and functionality. MultiDimension does not assume any liability arising out of the application and use of its products. MultiDimension's customers using or selling this product for use in appliances, devices, or systems where malfunction can reasonably be expected to result in personal injury do so at their own risk and agree to fully indemnify MultiDimension for any damages resulting from such applications.